



# Stack-Rack

## Vertical Receiver Mounted Cargo Rack Assembly and Use Instructions

### Assembly Tools Required:

- Adjustable Crescent Wrench
- 13mm Box Wrench or Socket
- 16mm Box Wrench or Socket
- 18mm Box Wrench or Socket

### Step 1: Attaching Column Tube to the Receiver Tube

The Column Tube is attached to the Receiver Tube using one 12mm x 80mm hex bolt, flat washer and locknut, and the 12mm curved clevis pin. Attach the Column Tube as shown in figure 1. Tighten the 12mm hex bolt securely, then reverse the nut until the column tube is free to rotate.

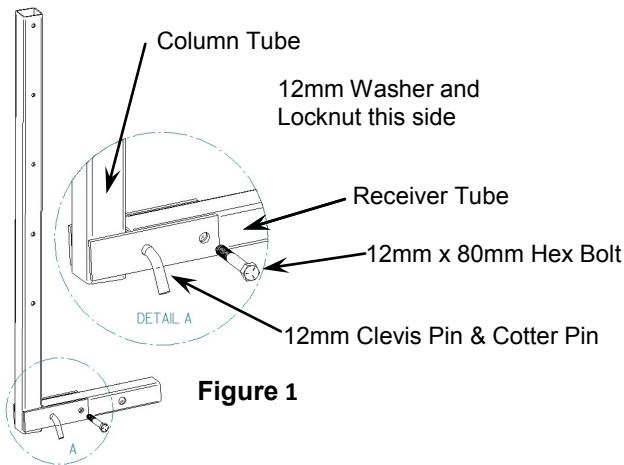

**Figure 1**

### Step 2: Rack Assembly

Position the port and starboard brackets onto the center of the cooler rack rear tube as shown in figure 2. Attach the brackets using two 8mm x 55mm hex bolts, washers and locknuts. Finger tighten only. Attach this assembly to the column tube at the desired position and secure using one 10mm x 70mm hex bolt, washer and locknut as shown in Figure 3. Tighten securely, then reverse the nut until the brackets rotate freely on the column tube. Now securely tighten the two 8mm x 55mm bracket bolts.

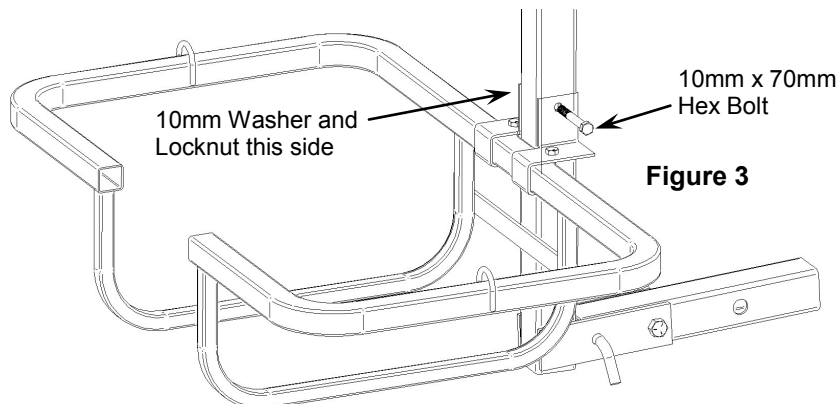

**Figure 3**

### Stack-Rack Parts Overview

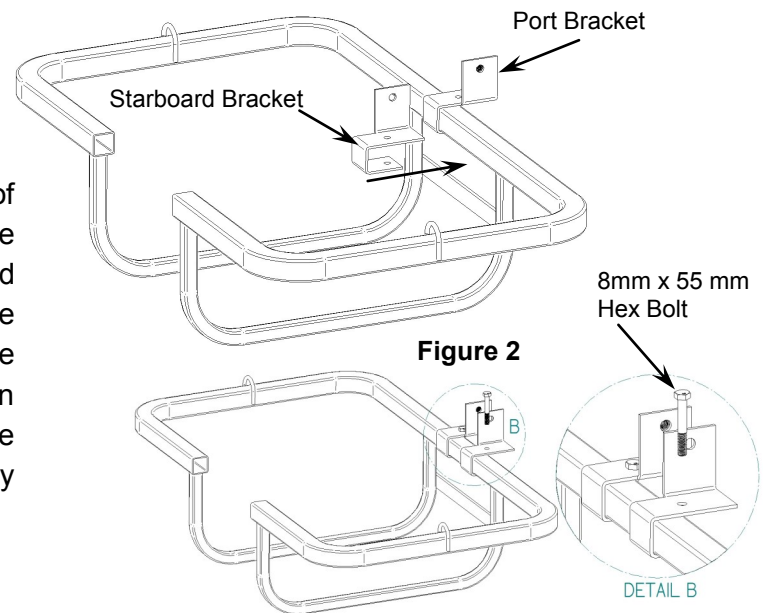
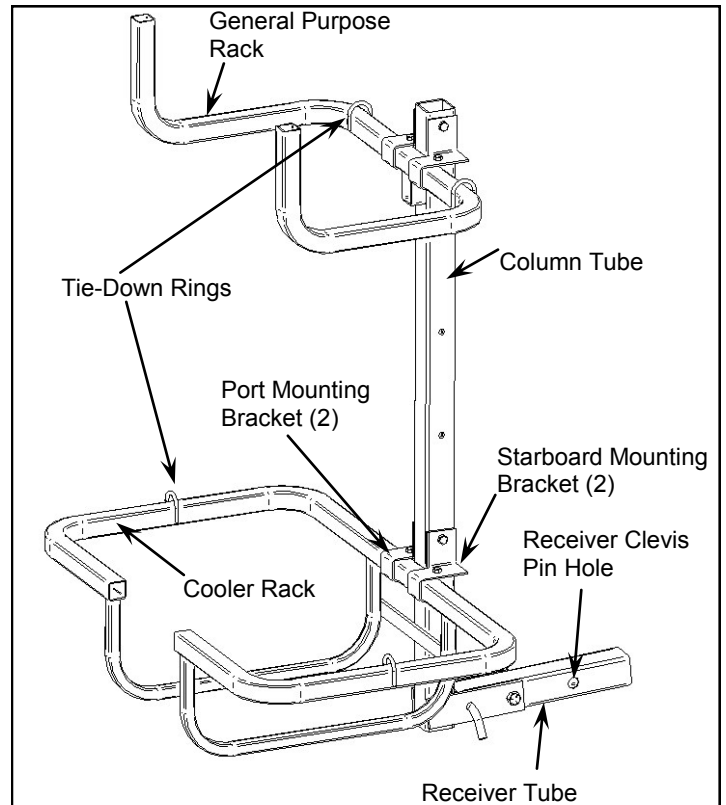

**Figure 2**

Step 3: Repeat Step 2 for the general purpose rack. Position the general purpose rack at the desired location on the column tube and secure using the same procedure in Step 2.



## WARNING !

### Instructions for using the Viking **Stack-Rack**

Failure to read and follow all instructions may result in property damage, serious injury or death.

- Never exceed the total maximum load capacity of 300 Lbs. (150 lbs. maximum each frame).
- Use appropriate tie-down straps to secure the load and always assure the load is balanced on the rack system.
- Always use caution to avoid pinch points during assembly, loading or use of the rack system.
- Never allow any cargo to extend beyond 36 inches from the tail lights of the vehicle.
- Never begin transporting any object until you are certain it is secured to the cargo frame(s).
- Never use for transportation of pets or live animals.
- Never load an object that is not fully contained within the rack frame(s).
- Always use additional caution during reverse operation of the vehicle.
- Always inspect for damage during storage, missing parts, etc. before each use.
- Store the **Stack-Rack** appropriately when not in use to provide years of trouble-free use.

### Set-up and Operation of the **Stack-Rack**

**Step 1:** Insert the receiver tube into a 2" Class III or Class IV receiver hitch (300 Lb. minimum tongue weight capacity) making sure to align the clevis pin hole with the mating hole on the receiver hitch. Secure with an appropriate locking clevis pin and cotter pin (not included). Important: **Do not use the Stack-Rack** before securing the receiver tube into the receiver with a locking pin.

**Step 2:** You may place a cooler, storage trunk, tool box, etc. in the cooler rack assembly. Always be sure the size of the item is appropriately secured by the frame size. Do not use for cargo transport if your item is not secured within the frame assembly. Next, use an appropriately rated tie-down or ratchet strap to restrain the cargo from movement during transportation. The same applies to the general purpose rack for transporting items like step-ladders, tailgate canopies, tents, camping gear (bag chairs, sleeping cots) etc. As before, always bind the items securely to the frame assemblies.

**Step 3:** Folding access to the cargo/truck bed area

If you need to lower the **Stack-Rack** to gain access to the cargo area of a SUV or the bed of a pickup, it is necessary to pivot the Stack-Rack away from the vehicle. This is conveniently done by first removing the re-usable cotter pin from the curved clevis pin. Next, push the column tube toward the vehicle to remove the load on the clevis pin, and remove the clevis pin while securely holding the top of the column tube. The column tube may be rotated slowly away from the vehicle until the lower frame is supported on the ground. Reverse this procedure to re-install the clevis pin and re-usable cotter pin. Always verify the pin is secure before proceeding with the vehicle.

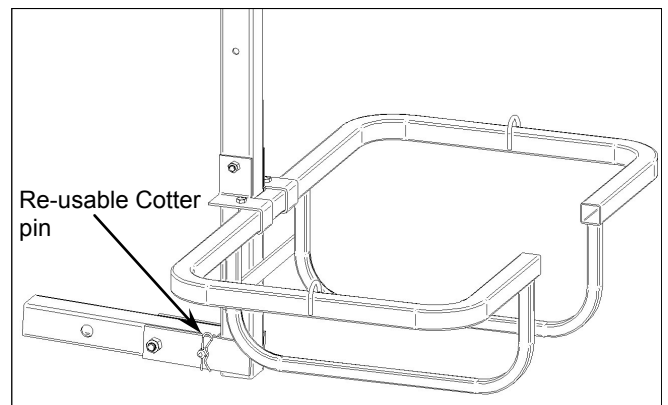
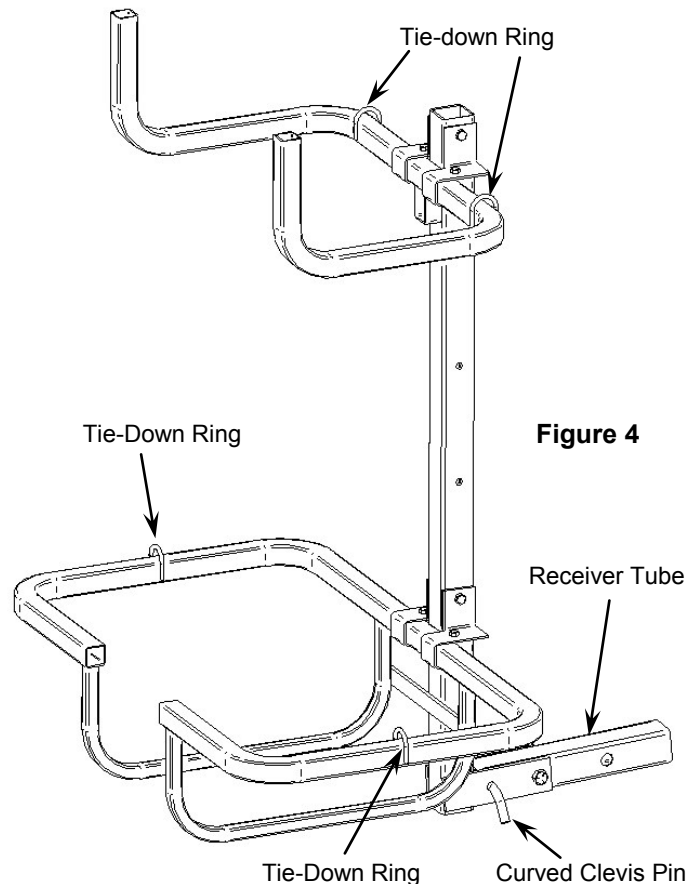

If there are any questions concerning the assembly and/or operation of the **Stack-Rack**, please call or email immediately for assistance.